

Assembly Overview and Part Names:

- A. T-bar Assembly
- B. Quick Release Lever
- C. Extension Tube with Folding System
- D. Knob
- E. Quill
- F. Wedge
- G. Stem Bolt
- H. Hex Key (6mm)
- I. Headset Lock Nut

Kit Contents:

- 1. Replacement Bolt
- 2. Washer
- 3. Wedge Assembly
- 4. Hex Key Wrench

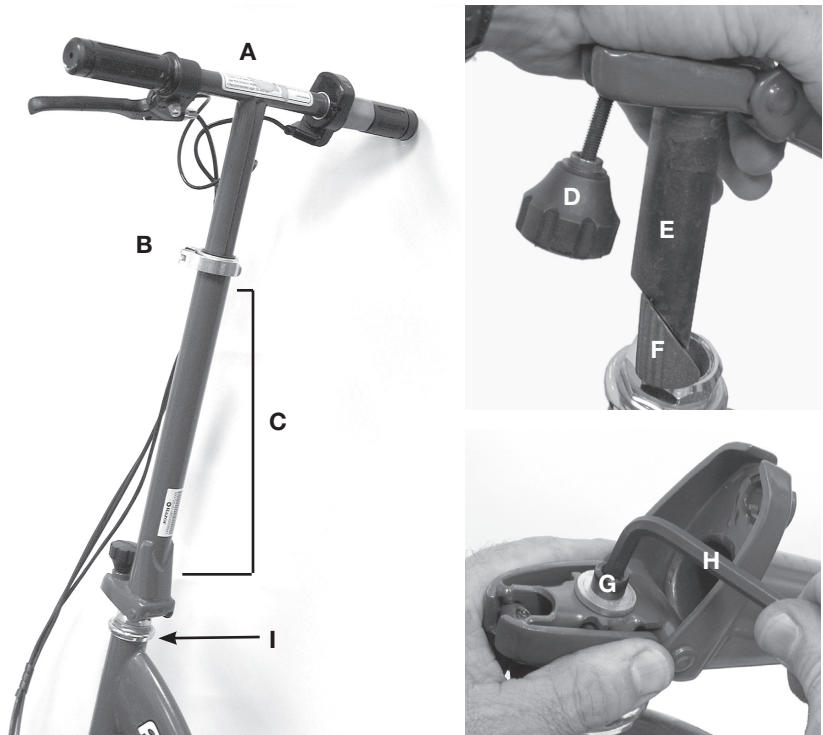

WARNING: Turn off the main power switch before proceeding with the following instructions.

Step 1: Loosen the Stem Bolt

Using the hex key, loosen, but do not remove, the stem bolt. Loosen the bolt 1-1/2 to 2 turns.

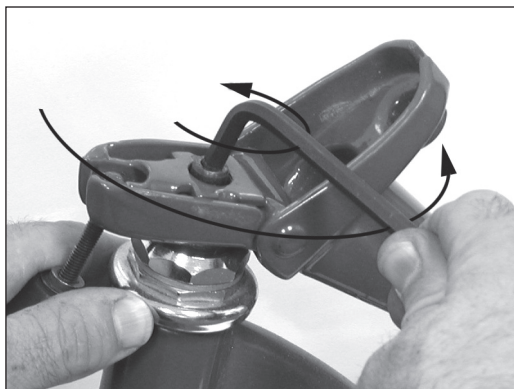

Step 2: Remove Folding System

With the stem bolt loose, you should be able to lift the folding system out of the fork as shown.

If needed, lightly tap on the top of the stem bolt with a small hammer to release the wedge from inside the fork and allow removal.



Step 3: Replace the Stem Bolt

Unscrew the original stem bolt from the wedge and remove. Insert the longer replacement bolt [3a] and the washer [3b] and thread the wedge [3c] in place until the bolt is 2 or 3 threads from the end. Do not tighten all the way.

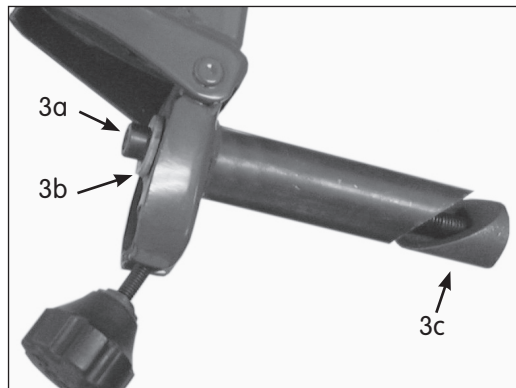

Step 4: Reinstall Folding System

Insert the folding system as shown. Insert all the way so the bottom plate of the folding system is touching the headset lock nut.



Step 5: Steering Alignment

With the folding system aligned roughly with the front wheel, lightly tighten the stem bolt. Upright the T-bar and visually check the alignment of the front wheel to the handlebar.

Carefully nudge the steering into alignment. When you are satisfied with the adjustment, fold the T-bar down and tighten the stem bolt securely as shown below. The correct tightness is when the front fork and wheel are securely clamped to the folding system and it can't be twisted out of alignment with any normal use or force.

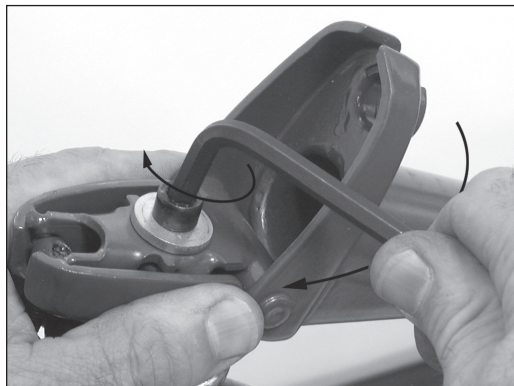

Step 6: Check Alignment

Take the scooter on a test ride to verify that the handlebar is properly aligned with the front wheel. If not, loosen the stem bolt and adjust accordingly. When satisfied, recheck all fasteners before riding your scooter.